

This system is certified to the following European Standards

| | |
|------------------------------|-----------------------------|
| 93/42/EEC¹ | Class 1 Medical Device |
| 73/23/EEC | Low Voltage Safety |
| BS EN 61010-1 | |
| 89/336/EEC | Radio Interference Immunity |
| BS EN 50081-1:1992 | |
| BS EN 50082-1:1995 | |
| BS EN 300-220-1 | |
| 2002/95/ECRoHS | Permitted Materials |

¹Alert-it Care Alarms are social aids designed and manufactured in accordance with 93/42/EEC as Class 1 Medical Devices. They are intended to improve the vigilance of carers to distressing side-effects of various diseases, such as Epilepsy and Dementia. They do not monitor vital physiological processes and should not be expected to diagnose any disease or predict the onset of any symptoms.

Support

For technical support please fax or EMail:
HELP: 0845 217 9951 (local call)
FAX : 0845 217 9953
Support@alert-it.co.uk

Designed by:
ITs Designs Ltd
Leicester
LE3 3LR UK

...using technology to care for carers



None of the components, including batteries should be disposed of as Domestic Waste. For information on disposal contact ITs Designs Ltd.

Alert-it Care Systems

P144 Bed Vacation (Weight) Sensor

Installation Handbook



One of a range of Alert-it Care Alarms available from:

Specification

Dimensions 19 x 10 x 0.8 cms.

Material of construction: Fibreglass reinforced nylon resin

Bed/Chair weight capacity: 200 kgs

Minimum weight of occupant 40 Kg

The P144 Bed Occupancy Sensor can be used with the whole range of Alert-iT Bedside Monitors (P154 or P139) or directly into many Nurse Call Systems (for which bespoke connectors can be provided).

The unit detects the user leaving their bed (or chair) by virtue of the reduced weight acting on one of the legs.

Installation



The bed/chair leg is positioned in the recess of the wedge. For beds it is recommended to use a leg near the headboard which carries greater patient weight.

On wheeled legs it is best to lock the wheels where possible as movement within the recess can affect the weight setting.

The Alert-it system has been designed with due regard to reliability and integrity. While it offers a highly vigilant monitoring method, it is always possible that a distress condition can go undetected for a variety of reasons (including malfunction) and in life threatening situations it is advisable to use the Alert-it system in conjunction with additional monitoring techniques (e.g. video). Neither the manufacturer nor its agent can accept legal responsibility to provide a system that is infallible.

Adjustment

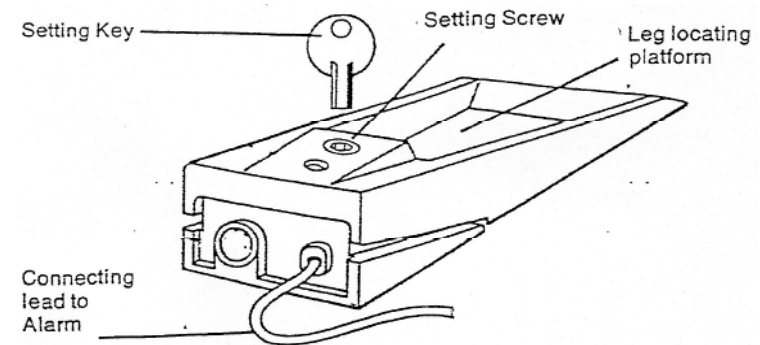

The unit must be calibrated for the bed weight to ensure maximum sensitivity to the user. This requires the use of an indicator to show operation of the unit, and inherent feature with the P154 or P139 Bedside Monitors.

The **P139** shows on the main monitor screen the word VACANT is the unit triggers, or OCCUPIED if not. To prevent an alarm during the setting it is advisable to set the Bed Occupancy time for 10 minutes (and the reset as required after)

The **P154** shows a red light against Input B if the unit has detected a VACANT condition. The adjustment should be made during the 30 second test period following pressing RESET, to prevent an alarm latching.

Using the red SETTING KEY, turn the adjustment anti-clockwise until the monitor indicates OCCUPIED. Now turn clockwise until the VACANT condition is indicated.

Have the user get on to the bed and test that in all the usual sleeping position that the OCCUPIED condition is indicated, and this changes to VACANT when they get out of bed.